

BS100C

HORIZONTAL BELT CONVEYOR (Slider Bed)

The BS100C belt conveyor is designed with channel frames and bolt-in pans making it ideal for matching up with other roller bed conveyors. It can be used in many types of material handling applications such as assembly operations, sorting, packaging, and inspection or for simply transporting product from point A to B.



- 15 belt widths
- Center drive and take-up
- Readily bolts up to other roller bed conveyors
- Multiple belt options

		CONVEYOR WEIGHT (LBS.)														
		BELT WIDTH														
OVERALL LENGTH	BED LENGTH	10"	12"	14"	16"	18"	20"	22"	24"	28"	30"	34"	36"	42"	48"	54"
		BETWEEN FRAME WIDTH														
		13"	15"	17"	19"	21"	23"	25"	27"	31"	33"	37"	39"	45"	51"	57"
		OVERALL FRAME WIDTH														
		16"	18"	20"	22"	24"	26"	28"	30"	34"	36"	40"	42"	48"	54"	60"
		4 IN. DIA. TAIL PULLEYS							6 IN. DIA. TAIL PULLEYS							
12'	10'	513	555	595	636	677	717	758	860	933	984	1,050	1,098	1,231	1,360	1,498
17'	15'	595	643	690	736	783	829	877	986	1,070	1,127	1,198	1,253	1,409	1,556	1,711
22'	20'	674	727	780	832	884	937	991	1,106	1,202	1,265	1,342	1,403	1,582	1,747	1,919
27'	25'	753	812	870	928	986	1,044	1,103	1,225	1,331	1,400	1,483	1,549	1,750	1,931	2,120
32'	30'	831	896	960	1,023	1,087	1,151	1,217	1,345	1,463	1,538	1,627	1,699	1,923	2,122	2,328
37'	35'	911	982	1,050	1,119	1,189	1,258	1,330	1,463	1,592	1,673	1,767	1,844	2,091	2,306	2,529
42'	40'	989	1,065	1,140	1,215	1,290	1,366	1,444	1,584	1,724	1,811	1,911	1,994	2,264	2,497	2,737
47'	45'	1,068	1,151	1,230	1,311	1,392	1,473	1,556	1,702	1,854	1,945	2,051	2,140	2,431	2,681	2,938
52'	50'	1,146	1,235	1,320	1,406	1,494	1,580	1,670	1,822	1,985	2,083	2,195	2,290	2,605	2,872	3,146
57'	55'	1,226	1,320	1,411	1,503	1,595	1,687	1,783	1,940	2,115	2,218	2,335	2,436	2,773	3,056	3,347
62'	60'	1,304	1,403	1,500	1,598	1,697	1,795	1,897	2,061	2,247	2,356	2,480	2,586	2,945	3,247	3,555
67'	65'	1,383	1,489	1,592	1,694	1,798	1,902	2,010	2,179	2,376	2,491	2,620	2,732	3,113	3,431	3,756
72'	70'	1,461	1,573	1,681	1,790	1,900	2,009	2,124	2,300	2,508	2,629	2,764	2,882	3,286	3,622	3,964
77'	75'	1,541	1,658	1,772	1,886	2,001	2,116	2,237	2,418	2,637	2,764	2,904	3,028	3,454	3,806	4,165
82'	80'	1,619	1,742	1,862	1,981	2,103	2,224	2,351	2,539	2,769	2,902	3,048	3,178	3,627	3,997	4,373
87'	85'	1,698	1,827	1,952	2,077	2,205	2,331	2,463	2,657	2,898	3,037	3,188	3,323	3,795	4,181	4,574
92'	90'	1,776	1,911	2,042	2,173	2,306	2,438	2,577	2,777	3,030	3,175	3,332	3,473	3,968	4,372	4,782
97'	95'	1,855	1,996	2,133	2,269	2,408	2,545	2,690	2,895	3,160	3,309	3,473	3,619	4,136	4,556	4,983
102'	100'	1,934	2,080	2,222	2,365	2,509	2,653	2,804	3,016	3,292	3,447	3,617	3,769	4,309	4,747	5,191

STANDARD SPECIFICATIONS

BELT – Black Trackmate 120 EMB

BED – 6 1/2 in. deep x 1 1/2 in. flange x 12 ga. powder coated steel channel frame with bolt-in slider pans and cross members. Standard 5 ft. and 10 ft. long bolt-together sections with splice plates.

CENTER DRIVE – Can be placed on any section of conveyor length. Minimum elevation is 17 7/8 in. Minimum OAL is 90". Chain guard is located on left-hand side when standing at infeed looking toward discharge.

DRIVE PULLEY – 8 in. dia. with 1 7/16 in. dia. shaft at bearing. Machined, crowned and fully lagged.

TAIL PULLEY – 4 in. dia. with 1 in. dia. shaft at bearing or 6 in. dia. with 1 3/16 in. dia. shaft at bearing. Machined crown.

SNUB ROLLERS – Adjustable 2 1/2 in. dia. rollers. Grease packed ball bearings. Includes guard.

RETURN ROLLERS – Adjustable 1.9 in. dia. rollers. Grease packed ball bearings

TAKE-UP – Located in center drive. Provides 16 in. of belt take-up.

BEARINGS – Sealed, pre-lubricated, self-aligning, ball bearings on drive and tail pulleys

BELT SPEED – Constant 65 FPM

SPEED REDUCTION – Sealed worm gear C-face speed reducer with No. 50 roller chain to drive pulley

MOTOR – 1 HP –230/460V – 3 phase – 60 Hz totally enclosed fan cooled, energy efficient

FRAME CAPACITY – Maximum load per linear foot of conveyor is 100 lbs. Not to exceed drive capacity in chart.

			LOAD CAPACITY (LBS.)				
			HORIZONTAL W/ STANDARD BELT				
FPM	HP	BELT WIDTH	8" DRIVE PULLEY				
			12'	32'	52'	77'	102'
35	1	10"-18"	1,200*	1,720	1,710	1,680	1,660
		20"-30"	1,200*	1,700	1,680	1,640	1,600
		34"-54"	1,200*	1,660	1,610	1,540	1,480
65	1	10"-18"	1,045	1,030	1,010	990	970
		20"-30"	1,030	1,000	970	940	900
		34"-54"	1,000	950	900	840	780
100	2	10"-18"	1,200*	2,095	2,080	2,050	2,030
		20"-30"	1,200*	2,070	2,040	2,000	1,970
		34"-54"	1,200*	2,020	1,970	1,900	1,840
135	1	10"-18"	720	700	685	660	640
		20"-30"	705	680	650	610	580
		34"-54"	680	630	580	510	450
135	2	10"-18"	1,200*	1,430	1,410	1,390	1,370
		20"-30"	1,200*	1,405	1,380	1,340	1,310
		34"-54"	1,200*	1,355	1,305	1,240	1,180
135	1	10"-18"	530	515	500	475	455
		20"-30"	520	490	465	425	395
		34"-54"	490	440	390	325	265
135	2	10"-18"	1,115	1,100	1,080	1,060	1,040
		20"-30"	1,100	1,075	1,045	1,010	975
		34"-54"	1,075	1,025	975	910	850

* Limited by conveyor capacity

Note: Capacities shown assume a constant speed and maximum of 6 starts/stops per minute with no more than 30 starts/stops per hour.

8" CENTER DRIVE

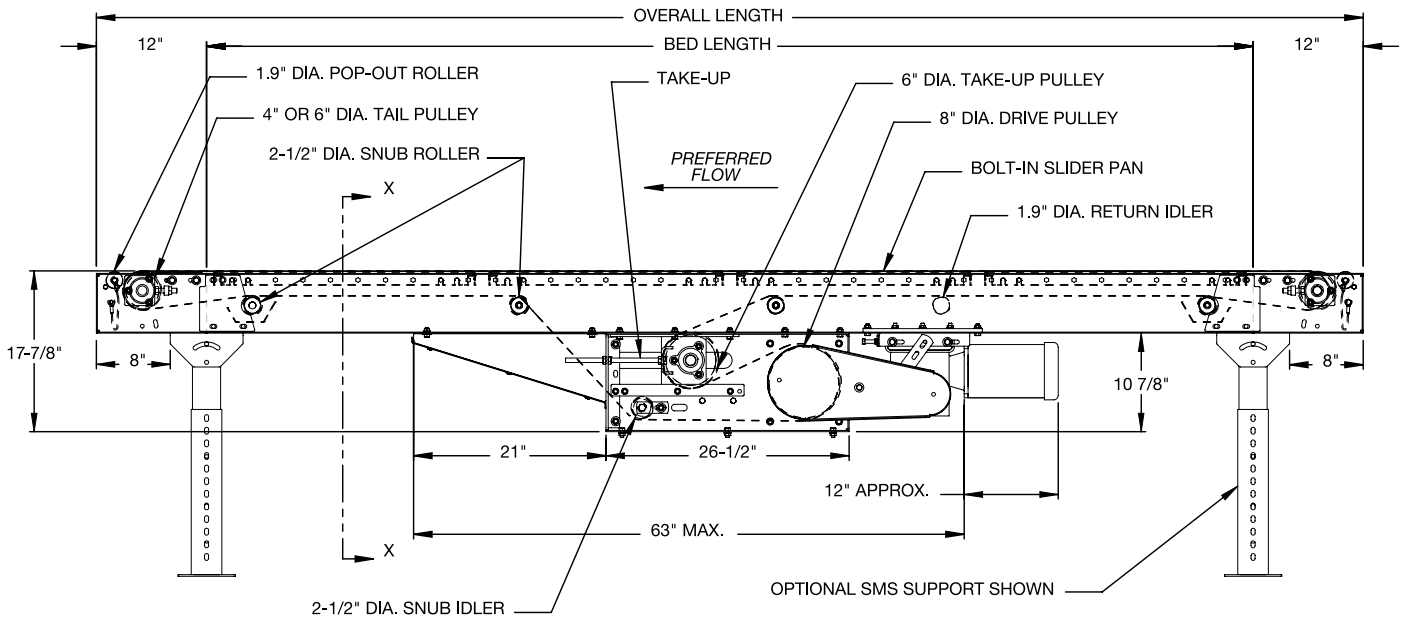

SECTION VIEW X-X

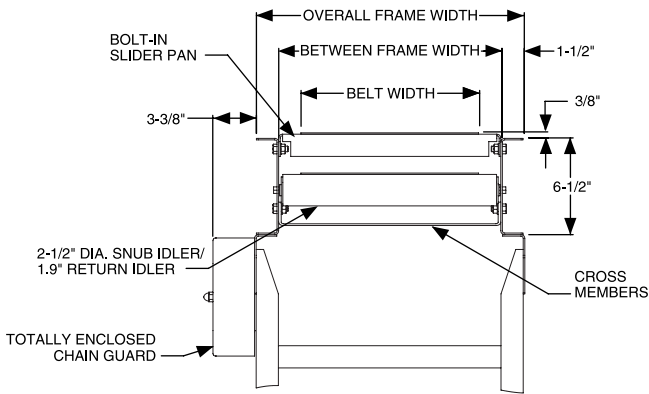

OPTIONAL EQUIPMENT

FLOOR SUPPORTS – SMS floor supports are available in wide range of adjustments. Specify top of belt elevation. One support is required at every bed joint and at ends of conveyor. Holes in feet are provided for lagging to floor. Knee braces supplied on SMS-7 support and above.

BELT – Tan Glidetop, White Polymate 100 RMP – COS, Black Trackmate 120 Roughtop with PVC cover

BELT SPEED – Other constant and variable speeds: 17 – 135 FPM in any increment. Contact factory for other speeds.

MOTORS – Inverter duty, premium energy efficient, single phase, brake motor, other characteristics. 2 HP maximum.

SIDE MOUNT CENTER DRIVE / TAKE-UP – Provides 16 in. of belt take-up. 16 1/2 in. minimum elevation. 78 in. minimum OAL.

END DRIVE – Requires underside take-up

- 8 in. underhung end drive: 16 in. minimum elevation. 104 in. minimum OAL.
- 8 in. side mount end drive: 13 in. minimum elevation. 96 in. minimum OAL.

UNDERSIDE TAKE-UP – Provides 16 in. of belt take-up. Extends down 15 7/8 in. from top of belt.

PULLEYS – 6 in. dia. tail with 1 3/16 in. dia. shaft at bearing in place of 4 in. when not furnished as standard

V-GUIDED CONSTRUCTION – When overall length to belt width ratio drops below 2.5:1 but is still greater than 1:1, V-guided belt is required to maintain belt tracking.

SLAVE KIT – To slave VBC19 curve from system end of belt conveyor

GUIDE RAILS – Adjustable channel guide rails, fixed angle and channel guide rails

OTHER ACCESSORIES – Floor supports with casters, poly-tier supports, ceiling hangers. See accessory section.

ELECTRICAL CONTROLS – One direction manual start switch, reversing drum switch, non-reversing and reversible IEC starters, push button stations, AC variable frequency drive.